

CNS Institute for Physics Teachers

Title:	Discovering Ohm's Law
Original:	17 October 2003
Revision:	11 July 2007
Authors:	George Wolfe, Alison Shull, Martin Alderman
Appropriate Level:	Regents/General Physics
Abstract:	<p>This tutorial/lab leads students through a series of readings and experiments to develop an understanding of voltage, current, and resistance, how simple circuits are diagrammed and wired, and how voltmeters and ammeters are used. The students collect and graphically analyze voltage and current data for a resistor in a simple series circuit. As the students interpret their graphs, they 'discover' Ohm's Law. The final phase of the experiment asks the students to test their understanding of the concepts in the lab by determining the resistance of a resistor which is unknown to them.</p>
Time Required:	Approximately two 40 minute class periods, depending on prior knowledge.
NY Standards Met:	<p>M1.1 Use algebraic and geometric representations to describe and compare data.</p> <p>M2.1 Deductive and inductive reasoning are used to reach mathematical conclusions.</p> <p>M3.1 Apply algebraic and geometric concepts and skills to the solution of problems.</p> <p>4.1.viii Measure current and voltage.</p> <p>4.1.ix Use measurements to determine the resistance of a series circuit.</p> <p>4.1.x Interpret graphs of voltage versus current.</p> <p>4.1.xiii Draw and interpret circuit diagrams which include voltmeters and ammeters.</p> <p>4.11 All materials display a range of conductivity. At constant temperature, common metallic conductors obey Ohm's law.</p> <p>4.1n A circuit is a closed path in which a current can exist.</p>
Special Notes:	Discovering Ohm's Law is a kit available from the CIPT Equipment Lending Library, www.cns.cornell.edu/cipt/ .

Behavioral Objectives:

Upon completion of this lab, a student should be able to:

- Define voltage, resistance, and current, and identify the appropriate symbols and SI units of each.
- Explain the underlying concepts of voltage, resistance, and current.
- Draw schematic diagrams of simple circuits, including proper placement of voltmeters and ammeters.
- Assemble simple circuits to match schematic diagrams.
- Interpret I vs. V and V vs. I graphs, and their slopes.
- Design and perform an experiment to determine the value of a constant unknown resistor given a battery, voltmeter, ammeter, and wires.
- Solve Ohm's law problems for simple single-resistor circuits.

Time Required:

- Approximately two 40 minute class periods, depending on prior knowledge.

Materials Needed:

- (1) 0-10. V DC Analog Voltmeter
- (1) 0-100 mA DC Analog Ammeter
- (4) Wires with alligator clips at one end and 'banana' plugs to fit the meters at the other end
- (3) Wires with alligator clips at both ends
- 100 Ω (Brown Black Brown), 1 watt resistor
- 150 Ω (Brown Green Brown), 1 watt resistor
- 1 watt 'unknown' resistor ($R \leq 500 \Omega$)
- Battery holder with 6 AA batteries (see photo)

Discovering Ohm's Law is a kit available through the CIPT equipment lending library, www.cns.cornell.edu/cipt/labs

Teacher Preparation Time Required:

10 minutes if using the CIPT kit. Please test the batteries as part of the preparation!

Assumed Prior Knowledge of Students:

Students are expected to have a working knowledge of static electricity, including atomic structure, charge, electric fields, and the interaction of charges.

Background Information for the Teacher:

The first part of this tutorial/lab is intended as a pre-lab or homework assignment.

If this lab follows the CIPT Water Circuits Lab, the teacher should take the time to point out the parts of the analogy that work well, and the parts that do not work well. The concept of a

ground and measurement of voltage relative to ground is an especially difficult concept for students that must be carefully explained by the teacher.

Answers to Questions:

1. Balance
2. The SI unit of electric charge is: Coulombs
3. Work is measured in joules.
4. Static electricity is called “static” because the charges are stationary.
5. Volts are a measurement of potential difference. Volts measure the potential energy needed per coulomb of charge moved between regions of different charge.
6. The potential difference is 2 V.
7. The potential difference is still 2 V.
8. Some lightning goes from the earth to a cloud, some goes from a cloud to the earth, and some goes from one cloud to another because mobile charges will always go from a high potential area to a low potential area, wherever it is. Sometimes a particular area on the earth is more positive than a cloud, and sometimes it is more negative than a cloud. Sometimes one cloud is more positive or negative than another.
9. Draw a schematic diagram with ... The student should draw a diagram similar to the one on page 3 of the pre-lab, and include labels on the diagram.
10. What is the meter reading of the total voltage of the batteries? Approximately 9 V
11. Predicted voltage = approximately 9 V This is because the connection to one side of the resistor is also the connection to the same positive side of the power supply as before, and the connection to the other side of the resistor is also the connection to the same negative side of the power supply as before. The positive side of the power supply is just as positive, and the negative side of the power supply is just as negative as it was before. Hence the voltage, or potential difference is the same as it was before.
12. Measured voltage = approximately 9 V. How do the measured voltage and the predicted voltage compare? The measured value will be very slightly different from the value obtained earlier. What other factors might influence the measurement here? The resistance of the wires themselves contributes to the error. Temperature might also be named as a factor which changes the behavior of the batteries, wires, and meters slightly.
13. ... why is this potential difference called a voltage drop? The resistor is reducing the available electrical potential energy per coulomb of charge, or potential difference. Hence the expression: voltage drop.
14. What is the energy relationship ...? The input energy must equal the output energy in the circuit. The energy relationship is the law of conservation of energy. (The voltage relationship is called Kirchhoff's voltage rule ... voltage rise = voltage drop).
15. The voltmeter connected across this resistor will read 12 V.
16. The student replaces the 10 Ω resistor with a 20 Ω resistor. ... $V = 12 V$ Note that the voltage has not changed as a result of the change in resistance.
17. Will the mass still use all of its potential energy as it falls through the water? Yes

18. How will the motion of the mass differ as it falls through the more resistant medium? The mass will fall much more slowly as it falls through the more resistant medium.
19. Measured current = approximately 90 mA = approximately .09 A Replace the 100 Ω resistor with the 150 Ω (Brown Green Brown) resistor, close the circuit, and read the new current as above.
20. Measured current = approximately 60 mA = approximately .06 A
21. The current through the 100 Ω resistance was (greater than, less than, the same as) the current through the 150 Ω resistance.
22. Hypothesis: As voltage applied to a resistor increases, current through the resistor will: increase Independent variable = Voltage Dependent variable = Current
 Controls = resistor, meters, and wires used. Temperature does not remain constant, but should not vary enough to cause significant error.

Number of batteries	Resistance (Ω)	Voltage (V)	Current (mA)	Current (A)
1	100	1.5	15	0.015
2	100	3.0	30	0.030
3	100	4.5	45	0.045
4	100	6.0	60	0.060
5	100	7.5	75	0.075
6	100	9.0	90	0.090
1	150	1.5	10	0.010
2	150	3.0	20	0.020
3	150	4.5	30	0.030
4	150	6.0	40	0.040
5	150	7.5	50	0.050
6	150	9.0	60	0.060

Current vs. Voltage

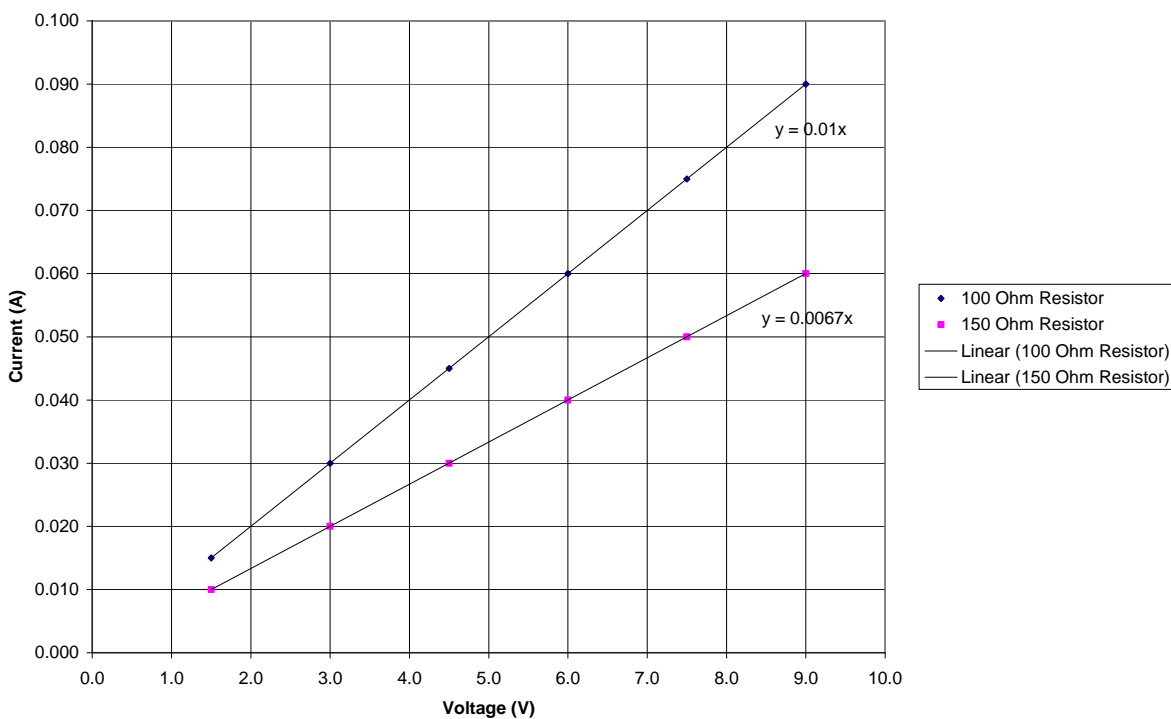

23. The slope of the line for the 100 Ω resistor is approx. 01, and its units are Amperes/Volt.
 24. The slope of the line for the 150 Ω resistor is approx. 0067, and its units are Amperes/Volt.
 25. For the graphs of I vs. V:

For R = 100 Ω

$$y = m \cdot x + b$$

\downarrow \downarrow \downarrow \downarrow

$$I = 0.010 \cdot V + 0$$

For R = 150 Ω

$$y = m \cdot x + b$$

\downarrow \downarrow \downarrow \downarrow

$$I = 0.067 \cdot V + 0$$

For the graphs of V vs. I:

For R = 100 Ω

$$y = m \cdot x + b$$

\downarrow \downarrow \downarrow \downarrow

$$V = 100 \cdot I + 0$$

For R = 150 Ω

$$y = m \cdot x + b$$

\downarrow \downarrow \downarrow \downarrow

$$V = 150 \cdot I + 0$$

Based on what you have written in item 25 above, write a simple equation for V using I for current, R for resistance, and G or S for conductance.

$V = IR$ or RI Students might also correctly put $I(1/G)$ or $(1/G)I$, but the teacher should explain that in practice, the first form is the one that is most useful. **Many students will guess the slope of their graph is resistance.** The students keep resistance constant and vary the voltage. The voltage is the independent variable, plotted on the X axis, and current is the dependent variable, plotted on the Y axis. The students will see that an increase in voltage causes an increase in current. If they did the activity correctly the slope will be $1/100$ rather than 100. The slope is I/V and is equal to $1/R$. Combining the two: $I/V = 1/R$ or $V=IR$.

If students are incorrect at first, encourage them to check their incorrect prediction, and figure out what they misinterpreted.

26. Conductance and resistance are related in a simple mathematical way. What is it? The conductance and resistance are reciprocals of each other.

27. Verifying the Relationship

The values of the unknown resistors will vary. The remaining answers show a sample calculation for R = Red Red Brown Gold, or $220 \Omega \pm 5 \%$

	Sample Calculations:
Voltage = <u>9.0 V</u>	$V = IR$
Current = <u>40 mA</u> = <u>0.040 A</u>	$R = V/I$
	$R = 9.0 \text{ V}/0.040 \text{ A}$
	$R = 225 \Omega$
Calculated Resistance = <u>225 Ω</u>	

28. According to the color code on the ‘unknown’ resistor, $R = 220 \Omega$ and the tolerance is $\pm 5 \%$

29. This means that the ‘unknown’ resistance should be $220 \Omega \pm 11 \Omega$

30. Is the calculated value within this range?

Yes. 225Ω falls within the range $209 \Omega - 231 \Omega$.

31. One last test to see if you’ve got it: a resistor coded red, red, orange, gold will have a resistance of $22,000 \Omega$ or $22 \text{ K}\Omega \pm 1100 \Omega$.

Tips for the Teacher:

- Two to three students/group is recommended. Strategizing the answers is important.
- The pre-lab should be done as homework and gone over in class to assure that all the students start ‘on the same page’.
- Circulate among your students. They find the electrical connections in this and experiments on series and parallel circuits to be very confusing, and will undoubtedly want you to check that they are ‘doing it right’. Try to answer with questions rather than direct answers. Although the diagram towards the end of the lab shows both meters in the same schematic diagram, it is clearer and easier to avoid having students use voltmeters and ammeters simultaneously in the same circuit. Do voltage and current measurements as separate steps!

- A good technique to use at the point where lab groups are interpreting their graphs is to ask what their equations are. If there are different equations, they can be posted as different ‘theories’ and evaluated after everyone has completed the investigation.
- This exercise uses analog meters in order to avoid the complexity of multi-meters in an introductory lesson on circuits and wiring.
- Graphing Current vs. Voltage will result in a slope of $1/R$, not R .
- Students tend to put too much faith in the precision of analytical instruments. We recommend you do a brief review of acceptable error.
- 9. The ammeters are calibrated in milliamperes. We recommend you do a brief review of conversions. Many students will plot current in milliamperes. Be sure to check for this error while they are working

Equipment List

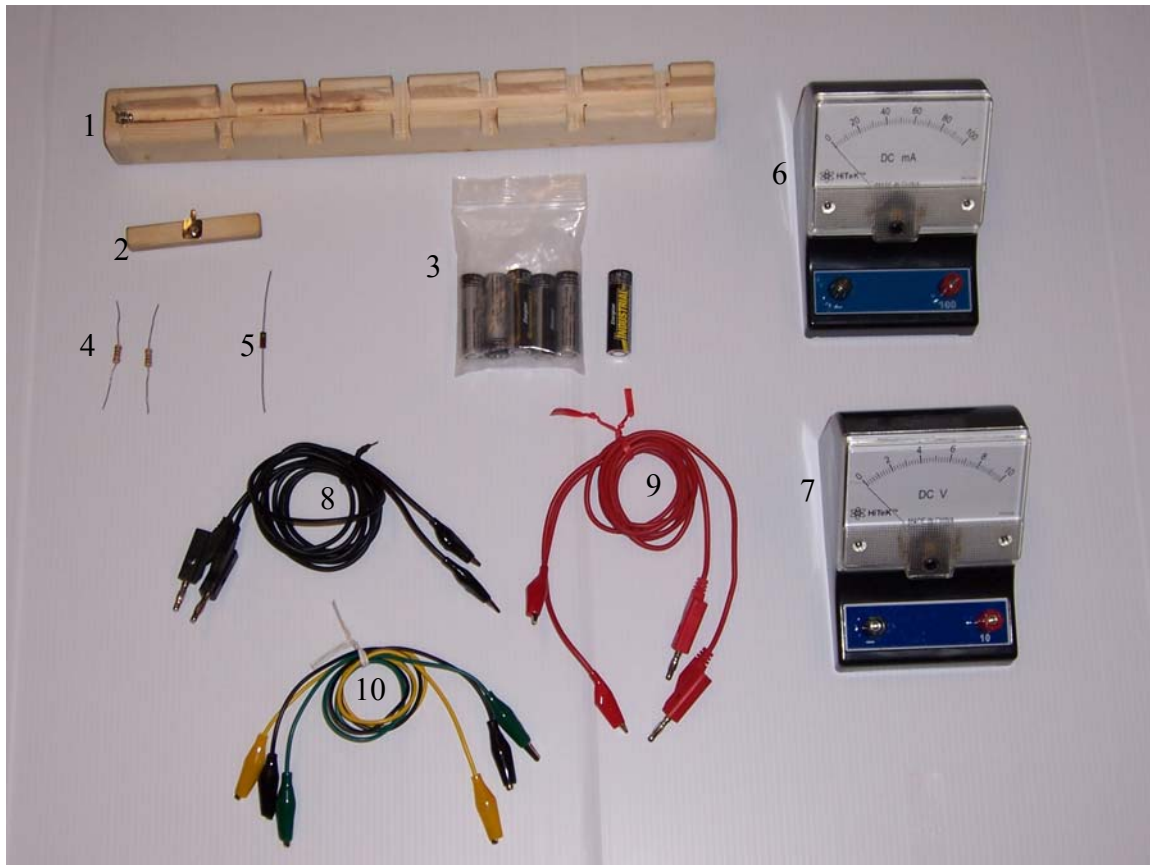

Item Number	Quantity	Item
1	1	Battery holder
2	1	Battery holder cross bar
3	6	AA batteries
4	2	100 Ω 1 Watt resistors
5	1	220 Ω $\frac{1}{2}$ Watt resistor
6	1	Meter DC 0-100 mA
7	1	Meter DC 0-10 V
8	2	Black banana - alligator test leads
9	2	Red banana - alligator test leads
10	3	Alligator – alligator test leads

DISCOVERING OHM'S LAW

Name _____

Class, period _____

Pre-lab - Components of a Circuit: The Big Three

Having recently examined the concepts of static electricity, a summary is in order:

1. _____ electrons can be relatively easily removed from an atom, because they are located in the outer orbitals.
2. When these electrons are added to or removed from an object, static charge builds up. The SI unit of electric charge is: _____.
3. In order to remove these electrons from the atom, work must be done. This work is measured in _____.
4. Static electricity is called "static" because _____.

The First Component: Voltage

OK, so now you are an expert on static electricity. You remember that electrons can be removed from atoms and it takes work to remove them. You also remember that most discussions of electricity use coulombs of charge rather than individual electrons since electrons have so little charge individually. A coulomb of charge is equal to 6.25×10^{18} elementary charges but coulombs of charge are usually more practical to work with than elementary charges. (It is similar to: 'A dozen eggs' is more convenient to purchase than the 12 eggs individually.) 'Static' means standing still. Static electricity means charge is accumulated and stationary in one place; thus the term "static."

When work is done on anything, energy is stored or used. If the amount of energy is a function of position, separation of + and - charges in this case, then it is *potential* energy. When work is done on static charges, its result is *electrical* potential energy. The more work done on a coulomb of charge, the more electrical potential energy is stored. When one joule of work is done on one coulomb of charge, the result is one joule of electrical potential energy. Twice as much work will result in twice as much stored electrical potential energy. This potential energy per unit of charge (joules/coulomb or J/C) is called 'electrical potential' or simply 'potential.' The only physically measurable quantity here is *difference* in potential energy. Therefore, one actually works with the 'difference of potential' or 'potential difference.' The standard SI unit for a potential difference of one J/C was renamed the **volt** in honor Alessandro Volta. The symbol used for voltage in equations is 'V'.

Voltage is roughly analogous to lifting an object against gravity. The higher you lift it, the more work you do, and the greater the resulting gravitational potential energy difference. An object lifted 2 meters has twice the 'gravitational voltage' of an object lifted one meter. So...

5. Volts are a measurement of _____.
6. If two joules of work are done on one coulomb of charge, the potential difference is _____.

7. If one joule of work is done on half a coulomb of charge, the potential difference is _____.

Circuits: Releasing the Potential Energy

If a coulomb of static charge has a certain voltage, some work must have been done on the charges in order to create that potential difference. Much as an object lifted above the Earth to a higher gravitational potential energy can be released and allowed to fall, charges can be 'released' if given a place to go. If they are allowed to, electrons will travel in the direction that will reduce extremes of charge and thus reduce their electrical potential energy. Electrons will go from an area of negative charge to an area of positive charge, from an area of extremely negative charge to an area of slightly negative charge, or from an area of slightly positive charge to an area of extremely positive charge to reduce potential difference. All that is needed is to give the electrons a complete path, or 'circuit.'

Lightning is a very extreme example of this. It begins with a huge buildup of electrons in one area and positive ions in another. Eventually, the electrons are pulled towards the more positive environment.

8. Why does some lightning go from the earth to a cloud, some go from a cloud to the earth, and some go from one cloud to another?

If one does work on electrons, 'raising' them to a higher electrical potential, it is called voltage rise. Connect the electrons to a place where there are not as many electrons, and they will experience an electrostatic force, and move from the high potential area to the low potential area. It is like gravitational force causing water to 'flow' downhill. Electrons will move from an area of great electrical potential energy to an area of less electrical potential energy. This lowering of electrical potential energy is called voltage drop.

Batteries, generators, and photovoltaic (solar) cells are a few of the devices that can do work to separate electrons from their atoms, creating a potential difference, a voltage, between their terminals (end connectors). If the electrons are provided with a path to do so, they can travel the 'circuit' from the negative terminal back to the positive terminal as diagramed here:

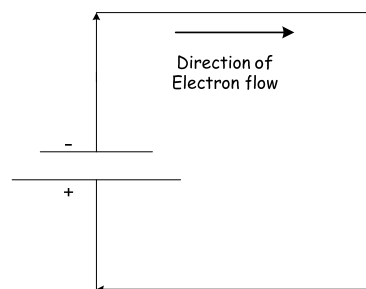

In a very real way, electrons are attracted to the positive terminal and repelled by the negative terminal. The negative electrons are releasing their energy as they move through the circuit, like a compressed coiled spring does when it is released. Any material that connects the terminals and allows the flow of charge is called a "conductor." The circuit diagram here is called a schematic diagram, or

simply, a 'schematic.' A schematic is a simple, functional symbolic 'picture' of an electric circuit. The directional arrows shown here are *not* generally included in schematic diagrams.

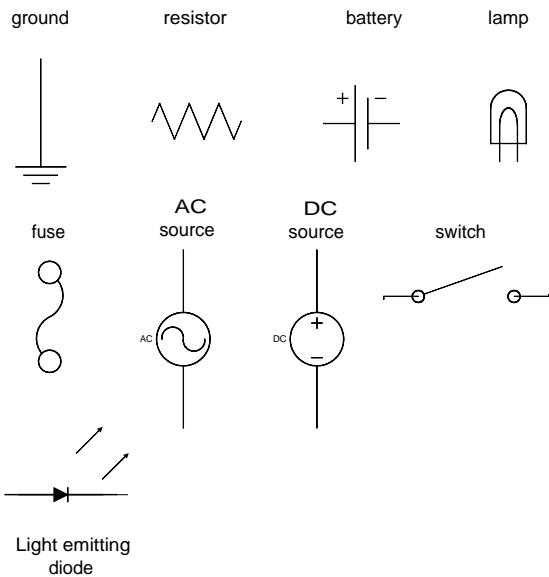

There are many symbols, like those shown to the left, that are fairly universally used in circuit diagrams, making it easy to communicate what a circuit is like.

Here is a simple circuit with a battery, switch, and resistor:

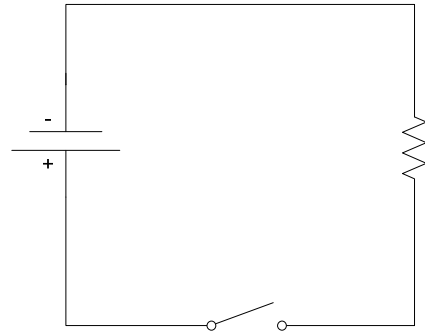

The Second Component: Current

How does charge move through a conductor? Electrons do not flow through a conductor like water through a pipe. The electron that enters a conductor from the negative terminal of a power supply is not the same one that exits to the positive terminal at the other end. One electron must exit the wire for each electron that enters in order to maintain a balance of charge, but it is not the *same* electron! Nor do electrons ‘bump’ each other along in a series of billiard-ball-like collisions!

As you know, conductors are made of atoms that hold the electrons in their outer, or valence shells very loosely. You also know that electrons moving through a circuit react to electric fields; attracted to the positive terminal and repelled by the negative terminal of the power supply all at once. Conductors like copper wire are not hollow pipes, but rather, are densely packed masses of atoms. As electrons move through the wire, pushed *and* pulled by the electric field provided by the power supply, they jump from atom to atom. The moving electron might associate with an atom, forcing another electron in the atom to move on, or it might simply bounce off an impurity or a fault in the metallic lattice structure, and onto a slightly different path. This later ‘bounce’ is especially important, and is called ‘scattering’. At the very same time, the positive terminal of the power supply either attracts an electron moving through the metal lattice, or attracts an electron from a nearby conductor atom’s valence orbital, leaving behind a positive ion. That ion is immediately given an electron due to the simultaneous repulsion of electrons from the negative terminal *and* attraction of electrons to the positive terminal. This "chain reaction" of electron responses to attractions and repulsions produces a directed drift of electrons from the negative terminal of the power supply, through the conductor, to the positive terminal. This directed drift of electrons is called an electron current, and the rate at which electric charge moves through the circuit is simply called current. The symbol used for current in equations is ‘**I**’.

[Another equally legitimate view of this process says an electron attracted out of a neutral conductor atom into the positive terminal of the power supply leaves behind a positive ion. This positive ion has a location in the valence shell where an electron could be placed, called a positive hole. When an electron from the next atom back from the positive terminal jumps in to fill the positive hole just formed, it leaves behind another positive hole. Thus, as electrons progress toward the positive terminal, positive holes progress toward the negative terminal. This is called conventional current or standard current. Electron current and standard current are just two different views of the same process, and both are commonly used. Most high school physics courses use electron current and most college courses use standard current, but both are perfectly acceptable explanations of how charge ‘flows.’]

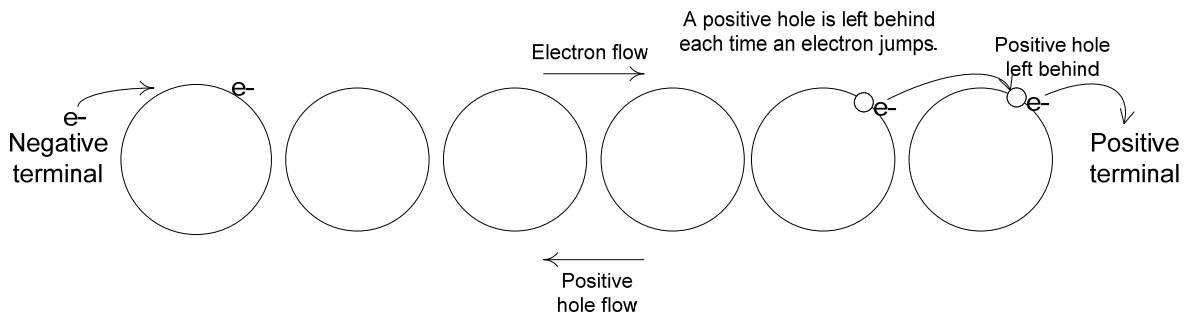

This diagram shows part of a current flowing through a series of atoms in a conductor. Your mission is to complete the diagram, showing how electrons and positive holes move through the conductor. The units of current will be discussed after you have done part of the lab.

The Third Component: Resistance

Are all conductors created equally? Will all substances allow electrons to flow the same? Different atoms hold their valence electrons with different amounts of force. Some atoms are harder to ionize than others, making it more difficult for current to flow. Electron scattering, mentioned in the last section, *significantly* influences the difficulty with which current flows. The amount of opposition to the free flow of current in a circuit is called the resistance. Resistance is measured in Ohms, the SI unit named after Georg Simon Ohm. It is symbolized by the Greek letter omega (Ω). All of the parts of a circuit have some resistance, including the wires themselves! The symbol used for resistance in equations is '**R**'. The opposite (reciprocal) of resistance, called conductance, tells the ease of current flow in a circuit. Conductance is measured with the SI units: mhos or Siemens.

9. Draw a schematic diagram with a battery, a resistor, and a switch in a complete circuit that has only one path for charge to follow. Single path circuits like this are called series circuits. Label the battery with $V = 1.50 \text{ V}$ and label the resistor with $R = 10 \Omega$.

(END OF PRE-LAB)

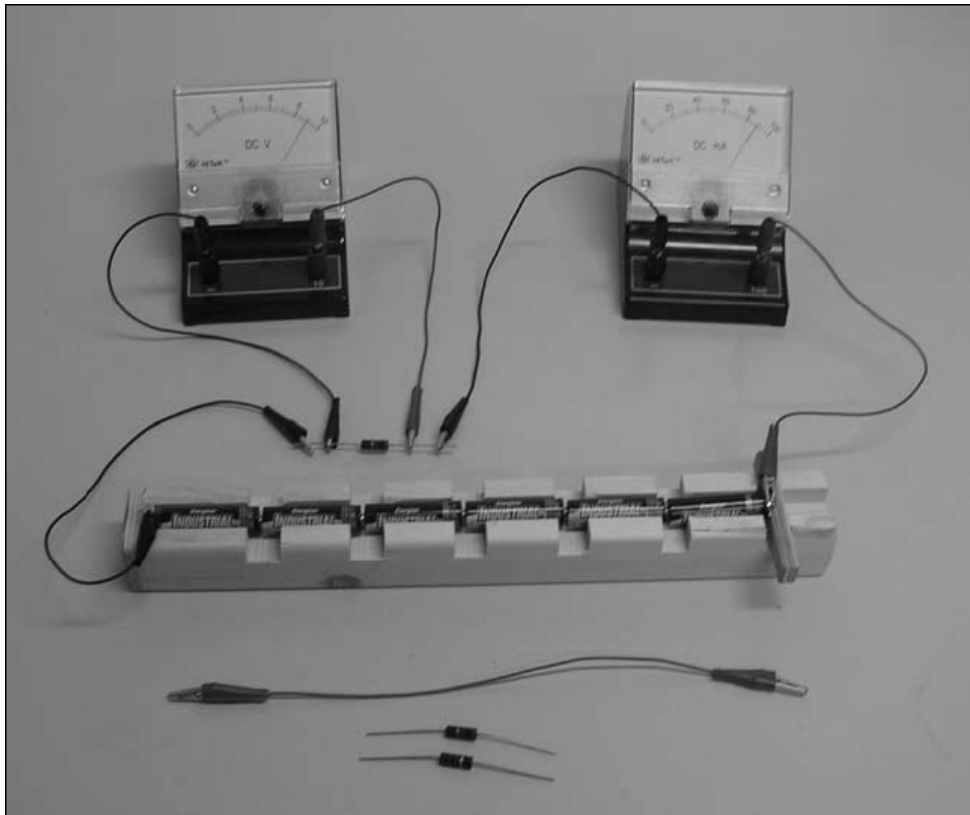

Measuring Voltage

Think about this scenario: Work is done on a group of electrons by a battery. Chemical bond energy is converted into electrical potential energy, as evidenced by the ‘separation’ of positive and negative charges to the terminals (ends) of the battery, and more directly by the usefulness of the battery in your mp3 player! The work done has created a difference of potential, or voltage. The question to be answered here is: How is the potential difference (voltage) of a battery measured?

Materials:

- Battery holder with 6 AA batteries (1.5 V each)
- 0-10 V voltmeter
- One 100 Ω resistor (Brown Black Brown)
- One 150 Ω resistor (Brown Green Brown)
- Two wires with ‘alligator clips’ on one end (they look a little like alligator jaws) and ‘banana plugs’ on the other end (shaped a little like bananas).
- Two wires with alligator clips on both ends.

*** Note that this lab will not use actual switches. It is a simple matter to connect and disconnect circuits with alligator clips, instead.

Using a Voltmeter

Place six batteries in the battery holder, and test their voltage as follows:

- Insert banana plug wires into the binding posts of the voltmeter. While color-coding is not required, it does help avoid some connection errors. By convention, red is always used for positive (the terminal marked with '10' on the meters used in this lab) and black is always used for negative (the terminal marked with '-' on the meters used in this lab).
- Clip the Red lead (wire) of the meter to the positive side of the battery holder and clip the black lead to the negative side. The polarity (plus or minus) is labeled on the side of each battery.
- The voltage of six 'AA' batteries laid end to end in series should be $6 \times 1.5 \text{ V} = 9.0 \text{ V}$ if the labels on the batteries are correct and no other factors have been missed.

10. What is the meter reading of the total voltage of the batteries? _____

If the reading is not exactly 9.0 V, that is not unusual, and is an indication of experimental variability that can be expected. One source of the variability has to do with labeling. The 1.5 V label used on batteries is not the actual voltage they supply, but rather a simple approximation intended to avoid confusing consumers. Different types of batteries, like 'alkaline', 'rechargeable', or 'heavy duty' actually produce slightly different voltages, but this does not significantly affect the devices they are used in.

- Disconnect the voltmeter from the battery pack and set up the open circuit shown here using the wires with alligator clips, the 9 V battery pack, the 100 Ω resistor (Brown Black Brown), and the 0-10 V voltmeter. Do NOT make the last connection, where the switch symbol is, until you are ready to actually measure the voltage in a few steps. (This will 'save the batteries' for later and keep the resistor from heating up.)

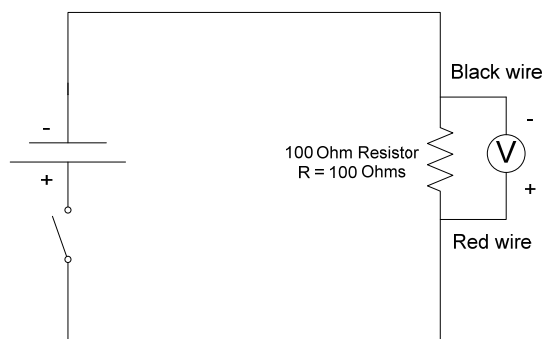

- A voltmeter measures how positive or negative one point in a circuit is compared to another point. This comparison is the work done (W in joules) per coulomb of charge moved from the higher potential connection point to the lower potential one, and the equation for this is $V=W/q$. Circuits with more than one path for current, like this one, are called parallel circuits. Most of the current goes through the resistor here, and only a very small amount goes through the very high resistance of the meter to power the meter, itself.

11. Before closing the circuit to measure the voltage, predict what it will be and support your prediction. Predicted voltage = _____ V Why this voltage?

Since this voltage is *provided* to the circuit, it is called 'voltage rise'.

Now, check to be sure the red (+) and black (-) sides of the meter are correctly connected. Close the circuit by connecting the unattached wire onto the battery pack. Read the voltage and open the circuit again by disconnecting the wire. If the meter goes backwards, the reading is negative, and the meter connections are reversed. Correct them and read the voltage.

12. Measured voltage = _____ V How do the measured voltage and the predicted voltage compare?

The voltmeter does have a tiny effect on this circuit because it uses a bit of energy just to function. The batteries, themselves, cause a bit more error in the circuit. This is because it takes a bit of energy to move charges through the internal resistance of the battery itself. The question here is: What other factors might influence the voltage measurement?

13. The voltage measured across a resistor is known as a "voltage drop". Voltage *is* potential difference, but why is this potential difference called a voltage drop?

14. The battery provides each coulomb of electrons at the negative terminal with roughly 9.0 joules of electrical potential energy (Input voltage is the voltage rise). The resistor, wires, and meter remove electrical energy from the circuit as charge moves through them, and ultimately convert the energy to heat (Output voltage is the voltage drop).

What is the energy relationship between the input energy and the output energy?

What is the voltage relationship between voltage rise and voltage drop?

Which fundamental law of physics is this, really?

Measuring Current

Setting the stage:

15. Suppose a student sets up a series circuit (one path) with a 12 V power supply and a 10 Ω resistor. A voltmeter connected across this resistor will read _____ V.
16. The student replaces the 10 Ω resistor with a 20 Ω resistor. What will the reading on a voltmeter connected across *this* resistor be? $V =$ _____ V

If you answered 12 V for both questions, you are correct. It makes sense that the same power supply would provide the same potential difference (voltage) to either resistor, but they were different resistors, so *something* must be different!

Consider a gravitational analogy. Imagine a 1.0 kg mass is lifted 2.0 meters and dropped. Clearly, when it hits the ground, it will have used all of the potential energy it obtained when work was done while lifting it. Now the experiment is repeated, but instead of dropping through air, the 1.0 kg mass is dropped the 2.0 m through a more "resistant" medium, water.

17. Will the mass still use all of its potential energy as it falls through the water? _____
18. How will the motion of the mass differ as it falls through the more resistant medium?

Hopefully, these questions helped you realize that electrons will move more slowly through a more electrically resistive medium when the potential difference is held constant much as in the case of the object falling through the more resistive water. Since electric current is the rate of flow of charge, the electrons moving more slowly means there is less electron current. While it makes some sense to measure current in electrons/second, the numbers would be huge, and it is more practical to use coulombs of charge/second. The SI unit of current, C/s was renamed the ampere in honor of André Ampère, but most people simply say 'Amp' for short.

Unlike a voltmeter, which measures potential difference, an ammeter measures the flow rate of charge as electrons move through a circuit. Instead of measuring across a circuit component like a voltmeter does, an ammeter is inserted right into the flow of charge. The ammeter is connected in series, which you will recall means that there is only one path for the charge to follow. Charge can not go through the component whose current is to be measured without also going through the ammeter because of this series connection!

Measurement of Current:

- Wire the open circuit diagrammed here, paying careful attention to polarity (+ and -). Use the 9 V battery pack, ammeter, 100. Ohm (Brown Black Brown) resistor and wires with alligator clips. Do not make the last connection, where the switch symbol is, until you are ready to actually measure the current.
- Notice that the ammeter has a range of 0-100mA. This means measured current will be in milliamperes, which can be converted to amperes by dividing by 1000.
- Check to be sure the red (+) and black (-) sides of the meter are correctly connected. Close the circuit by connecting the unattached wire onto the battery pack. Read the current and open the circuit again by disconnecting the wire. If the meter goes backwards, the reading is negative, and the meter connections are reversed. Correct them and read the current.

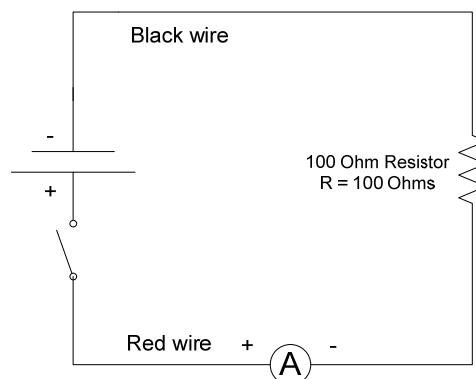

19. Measured current = _____ mA = _____ A

- Replace the 100 Ω resistor with the 150 Ω (Brown Green Brown) resistor, close the circuit, and read the new current as above.

20. Measured current = _____ mA = _____ A

21. The current through the 100 Ω resistance was (greater than, less than, the same as) the current through the 150 Ω resistance.

The Relationship among Voltage, Current, and Resistance

The measurements just made suggest there is some kind of numerical relationship among voltage, current, and resistance. It can be tested by applying various voltages to various resistors, measuring the resulting currents, and interpreting the outcomes. If examined graphically, the data might yield a functional equation that can be tested on any resistor. Let's get to it!

22. Hypothesis: As voltage applied to a resistor increases, current through the resistor will:

Independent variable =

Dependent variable =

Controls =

Set up the circuit shown here with the 100 Ω (Brown Black Brown) resistor, and test it with each combination of batteries shown in the table. When you have collected all the data for the 100 Ω resistor, switch to the 150 Ω (Brown Green Brown) resistor, and collect data for it.

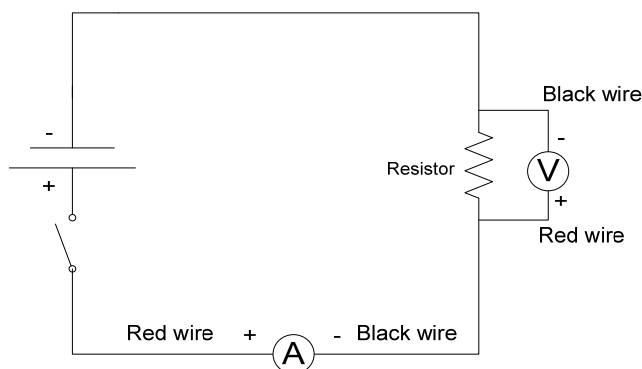

Number of Batteries	Resistance	Voltage	Current	Current
	(Ω)	(V)	(mA)	(A)
1	100			
2	100			
3	100			
4	100			
5	100			
6	100			
1	150			
2	150			
3	150			
4	150			
5	150			
6	150			

Look carefully at the data. There is a pattern in it, suggesting some kind of relationship exists. As already seen in this course, graphs usually provide the simplest way to examine relationships in data, leading to equations that put the pieces together.

Analysis: Plot a graph for the 100 Ω resistor with the independent variable on the x-axis and the dependent variable on the y-axis. Your teacher will tell you whether to graph by hand or computer.

- Hand drawn
 - Place small circles around each of the data points.
 - Draw in the best fit line or curve.
 - If straight, find the slope of the line using points that are exactly on the line.
- Computer drawn xy scatter plot
 - Use solid dots for the data points
 - Select the trend-line that matches the data best, and in trend-line options, select display the equation of the graph.

Now add the data for the 150 Ω resistor to the same graph, but key the points differently. (Use small squares around the points if hand-drawn, or small squares for the points if computer-drawn.)

You should have obtained straight line graphs.

23. The slope of the line for the 100 Ω resistor is _____, and its units are ____/____

24. The slope of the line for the 150 Ω resistor is _____, and its units are ____/____

25. Since straight line graphs were obtained, they *must* fit the equation: $y = mx + b$. Fill in the Y and X variable's in the following formulas with appropriate *symbols*: V for voltage, I for current, R for resistance, and G or S for conductance. Fill in the number you obtained for slope. The Y intercept, rounded to 1 significant figure, is probably very close to zero, so it is already in place.

For R = 100 Ω

$$\begin{array}{ccccccc}
 y & = & m & \cdot & x & + & b \\
 \downarrow & & \downarrow & & \downarrow & & \downarrow \\
 \underline{\quad} & = & \underline{\quad} & \cdot & \underline{\quad} & + & \underline{0}
 \end{array}$$

For R = 150 Ω

$$\begin{array}{ccccccc}
 y & = & m & \cdot & x & + & b \\
 \downarrow & & \downarrow & & \downarrow & & \downarrow \\
 \underline{\quad} & = & \underline{\quad} & \cdot & \underline{\quad} & + & \underline{0}
 \end{array}$$

Rewrite these equations as they would appear *if the x and y axes were reversed*.
 (Hint: slope = $\Delta y / \Delta x$ What happens to the slopes when the x and y axes are switched?)

For R = 100 Ω

$$\begin{array}{ccccccc}
 y & = & m & \cdot & x & + & b \\
 \downarrow & & \downarrow & & \downarrow & & \downarrow \\
 \underline{\quad} & = & \underline{\quad} & \cdot & \underline{\quad} & + & \underline{0}
 \end{array}$$

For R = 150 Ω

$$\begin{array}{ccccccc}
 y & = & m & \cdot & x & + & b \\
 \downarrow & & \downarrow & & \downarrow & & \downarrow \\
 \underline{\quad} & = & \underline{\quad} & \cdot & \underline{\quad} & + & \underline{0}
 \end{array}$$

Based on what you have written in item 25 above, write a simple equation for V using I for current, R for resistance, and G or S for conductance

$$V = \underline{\hspace{2cm}}$$

A straight line means there is a simple mathematical relationship between the slopes of these lines and one of the electrical characteristics discussed so far. What is it?

26. In fact, the slopes found here are the values of conductance, measured in mho or Siemens. Conductance and resistance are related in a simple mathematical way. What is it?

27. Verifying the Relationship

The relationship and equation you have hopefully just discovered is called Ohm's Law. Let's test it with a simple experiment. You have been provided with an 'unknown' resistor. Use the resistor, roughly 9.0 V of batteries, an ammeter, a voltmeter, and some wires to find the resistance of the 'unknown' resistor.

Calculations:

Voltage = _____ V

Current = _____ mA = _____ A

Calculated Resistance _____

How will you check whether your calculation was correct? The manufacturers of resistors provide users with the values of the resistors and their manufacturing tolerances through the use of color codes. Each colored ring on the resistors stands for a number. To read the code, hold the resistor with the gold or silver tolerance band on the right. The first color band is the first digit. The second color band is the second digit. The third color band is the number of zeros to write after the first two digits. The tolerance band tells the margin of error in manufacture and color coding of the resistor. The manufacturer states the color code will be correct within the tolerance range.

Resistor Color Codes

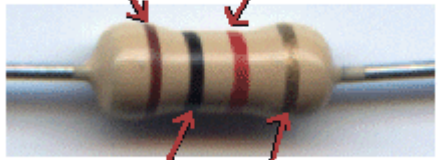

Color Band	value
BLACK	0
BROWN	1
RED	2
ORANGE	3
YELLOW	4
GREEN	5
BLUE	6
VIOLET	7
GRAY	8
WHITE	9

Tolerances

- Gold= 5%
- Silver=10%
- None=20%

28. According to the color code on the 'unknown' resistor, $R =$ _____ Ω and the tolerance is \pm _____ %

29. This means that the 'unknown' resistance should be _____ Ω \pm _____ Ω

30. Is the calculated value within this range? _____

31. One last test to see if you've got it: a resistor coded red, red, orange, gold will have a resistance of _____ Ω \pm _____ Ω